

Manufacturer's Declaration

VDE Application rule 2510-2 Stationary electrical energy storage systems for connection to the low voltage network

SUNGROW hereby confirms that the SH5.0RT, SH6.0RT, SH8.0RT, SH10RT Storage Energy Storage System meets the requirements of VDE-AR 2510-2.

Hefei, China, 2020-05-08
SUNGROW POWER SUPPLY

Johnny Zhang

Johnny. Zhang
System Solution Center

Energy storage system with SH5.0/6.0/8.0/10RT

The energy storage system for self-consumption optimization under an on-grid system consists of the following components:

- SH5.0/6.0/8.0/10RT
- SUNGROW Smart Energy Meter
- Battery (Approved Li-ion battery (see www.sungrow.com))

The energy storage system for self-consumption optimization under an on-grid or islanding system consists of the following components:

- SH5.0/6.0/8.0/10RT
- SUNGROW Smart Energy Meter
- Battery (Approved Li-ion battery (see www.sungrow.com))
- Backup Box (If necessary)

The energy storage system under an islanding system consists of the following components:

- SH5.0/6.0/8.0/10RT
- Battery (Approved Li-ion battery (see www.sungrow.com))

Information about VDE-AR 2510-2 Appendix A Functions for Network Replacement Operation/ Island Network Operation

A.1 Overload and short-circuit power supply

-Maximum overload current (effective value):

- SH5.0RT: 7.3 A
- SH6.0RT: 8.7 A
- SH8.0RT: 12.1 A
- SH10RT: 15.2 A

-Maximum overload power supply:

- Off-grid: 1.2 times overload power supply for maximum five minute
- On-grid: Immediate shutdown in case of overload

-Short-circuit current :

- Maximum short-circuit peak current: 202 A
- Duration until shutdown in case of exceedance 202 A peak (short circuit): 13 ms.

A.2 Voltage limitation

Voltage against earth during short-circuit power supply: <20 V

A.3 Island network in island network storage system

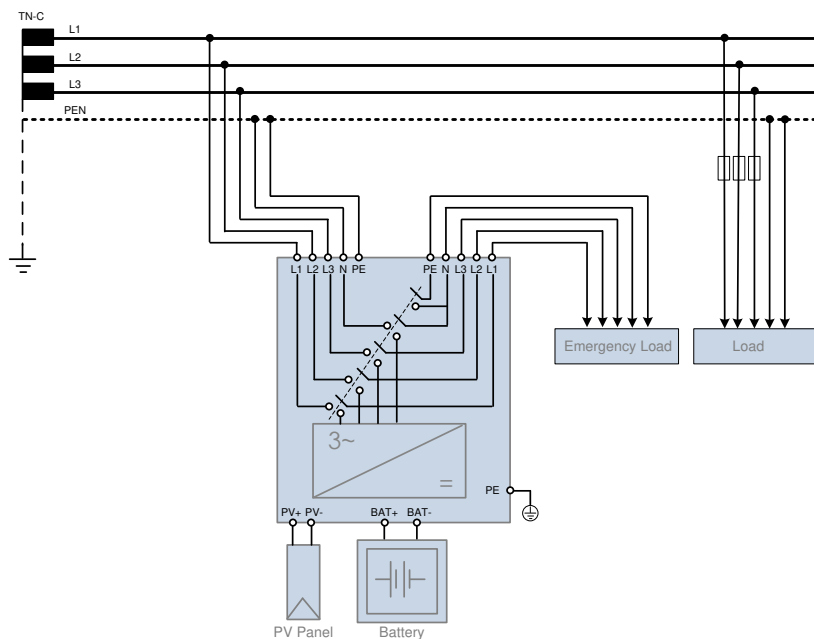

Fig-1 TN-C System

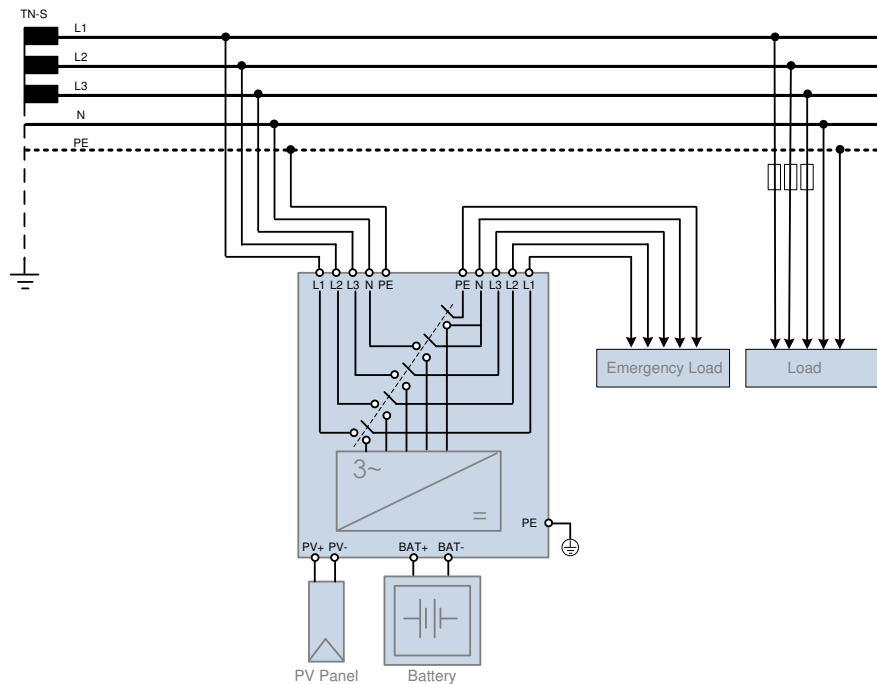

Fig-2 TN-S System

The island storage system (consisting of the components: hybrid inverter, PV panel, battery, Emergency load, load) shall be constructed in accordance with the above wiring diagram, complying with local rules and standards:

Measures to ensure one-fault safety in the battery inverter:

- Isolation monitoring of battery voltage
- N-PE connection monitoring

Island

Short-term electricity supply for the island network:

- SH5.0RT: 14.4 A for 10s
- SH6.0RT: 14.4 A for 10s
- SH8.0RT: 17.3 A for 5mins
- SH10RT: 17.3 A for 5mins

Permanent electricity supply for the island network:

- SH5.0RT: 7.2 A
- SH6.0RT: 8.6 A
- SH8.0RT: 11.5 A
- SH10RT: 14.4 A